

8

7

6

5

4

3

2

1

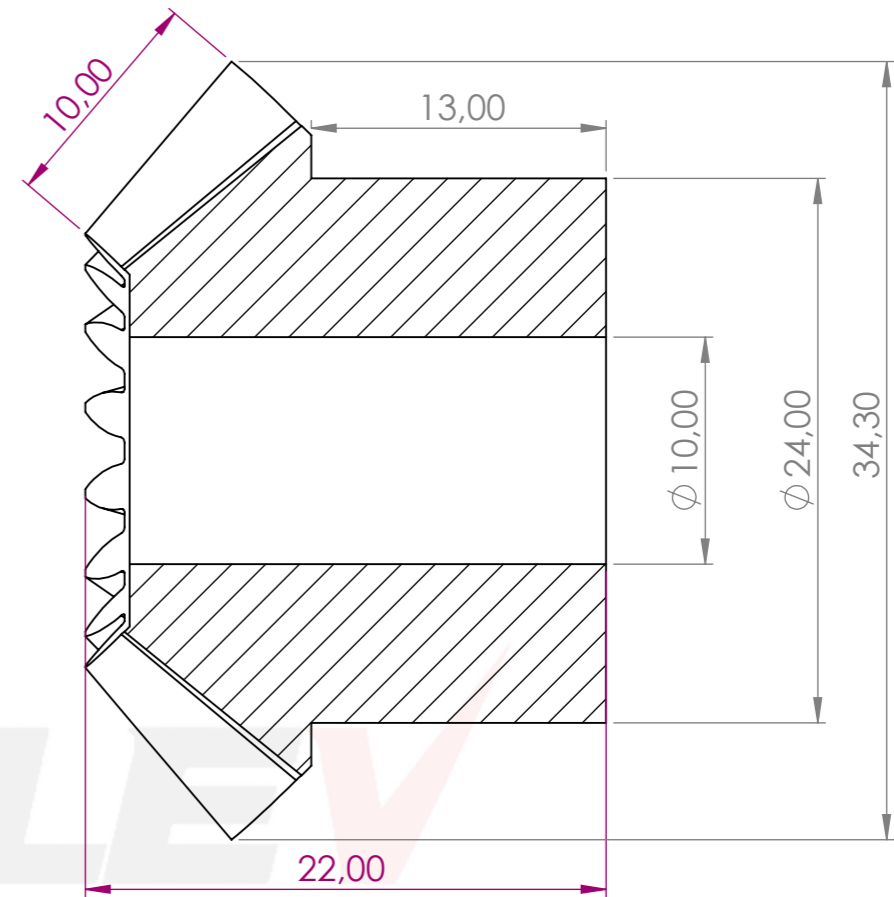
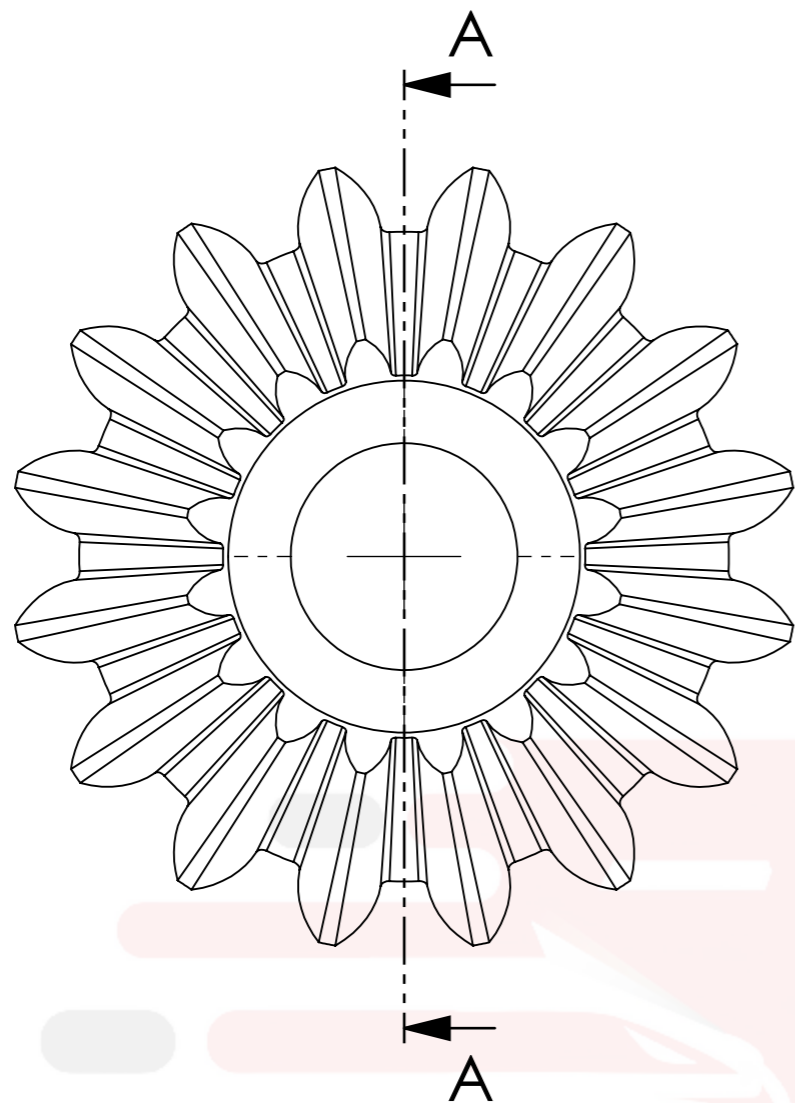

KESİT A-A
ÖLÇEK 3 : 1

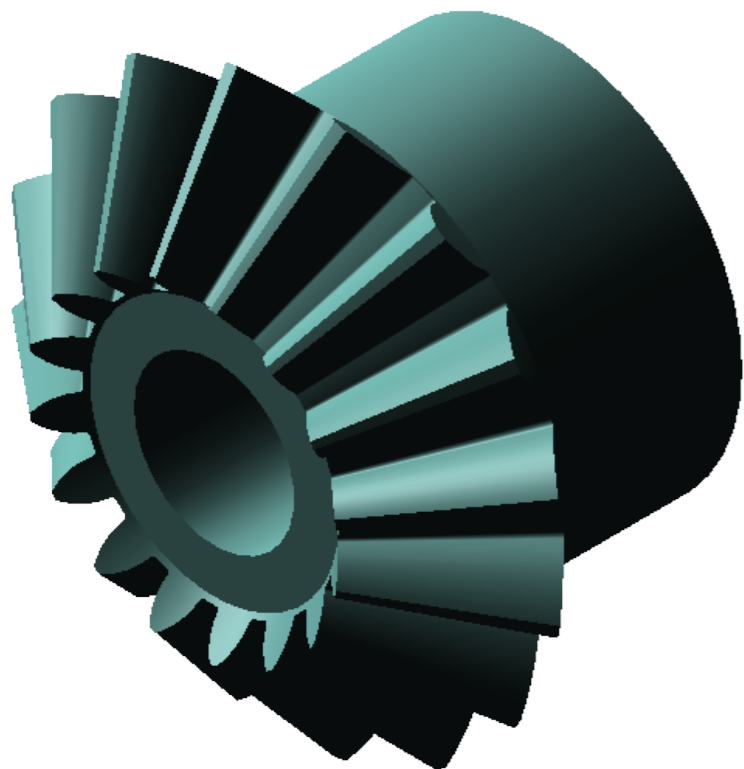

		KESİM ÖLÇÜSÜ / Cutting Size		MALZEME / Material			
ÇİZEN Drawn By	Mustafa ATİK	16.05.2026	S235JR (ST-37)		AĞIRLIK / Weight		ÖLÇEK / Scale
KONTROL Controlled By	Barış ŞAHİNOĞLU	16.05.2026	TEDARİK ŞEKLİ / Supply		68.78		ADET / Quantity
AÇIKLAMA Description		PARÇA NO Part No		REVİZYON NO Revision No			
BOYUTSAL TOLERANS (mm) Dimensional Tolerance		AÇISAL TOLERANS Angular Tolerance (±0°1')		PARÇA TANIMI Part Description		2 MODÜL Z16	
0,5<6	6<30	30<120	120<1000	0<10	10<50	50<120	PROJE ADI Project Name
0.05	0.1	0.15	0.2	+1'	+0,30'	+0,20'	

RESİM ÜZERİNDEN ÖLÇÜ ALMAYINIZ!

PEK A3-YATAY